

# dayzip

*daha fazla gün sikiştir*

## DZ-2528

5MP AHD DOME KAMERA



1/2.7"  
SENSÖR



2.8MM  
LENS



18 LED



IR

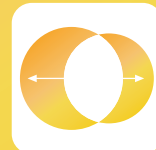

IR CUT  
FİLTRE



5MP



4in1



OSD



IP66



MAX.4W



/dayzip

0212 222 71 66

[www.cenova.com.tr](http://www.cenova.com.tr)



# DZ-2528

## 5MP AHD DOME KAMERA

# dayzip

daha fazla gün ışığı

### Genel Bilgi

- 1/2.7" 5MP CMOS Sensör
- Max Çözünürlük 5MP 2592x1944
- 2.8 Sabit Lens
- WDR, 2D/3D DNR,
- Hareket Algılama,

### Boyutlar

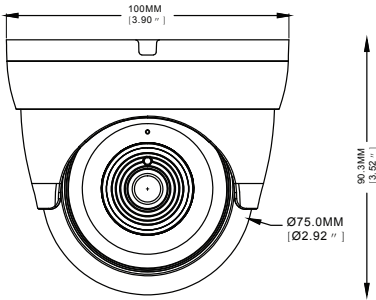

### KAMERA

### MENÜ

### ARAYÜZ

### GENEL

### Teknik Özellikler

Görüntü Sensörü	1/2.7" Progressive CMOS
Görüntü Formatı	PAL/NTSC
Kare Hızı	"5AHD/5TVI: 5MP@20fps 4AHD/4CVI/4TVI: 4MP/P@25fps 4MP/N@30fps CVBS: 960H "
Çözünürlük	5MP 2592 (H) ×1944 (V)
Aydınlatma	0.05lux@F1.2(AGC ON),0Lux with IR ON
Denkleşör	1/15 s to 1/50,000 s
Lens	2.8 mm Sabit lens
Yatay Görüş Alanı	H.FOV:81.04°(W)—28.78°(T)
Gündüz/Gece	IR cut filtre
IR Cut Filtre	Var,850nm
Senkronizasyon	Dahili senkronizasyon
Dwdr	Destekler
AGC	Destekler
Gündüz/Gece Modu	EXT / Otomatik / Renkli / BW (Siyah Beyaz)
Beyaz Dengesi	Otomatik/Manuel
BLC	Var
S / N Oranı	35dB
OSD	destekler
Video Çıkış	1-Kanal BNC Video Çıkışı
Anahtar Düğmesi	TVI/AHD/CVI/CVBS
IP Derecelendirme	IP66
Güç Kaynağı	DC12V
Güç Tüketimi	Maks. 4W
İletişim	Koaksiyel, Protokol
IR Mesafesi	20m'e kadar
Led	18pcs(SMD)
Boyutlar	Ø100 x 90.3MM
Ağırlık	-
Çalışma Sıcaklığı	-30~+60°C
Depolama Sıcaklığı	-30~+55°C

\*Cenova BT ürün ve ürün özelliklerinde değişiklik yapma hakkını saklı tutar. En güncel veriler için firmamıza başvurun.

# dayzip